



N-Ch 80V Fast Switching MOSFETs

Features

- ★ Advanced Trench MOS Technology
- ★ 100% EAS Guaranteed
- ★ Fast Switching Speed
- ★ Green Device Available

Applications

- ★ High Frequency Switching and Synchronous Rectification.
- ★ Power Tools.
- ★ Motor Control.

Product Summary



BVDSS	RDSON	ID
80V	3.4mΩ	180A

TO263 Pin Configuration

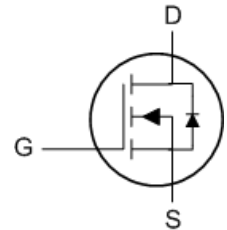
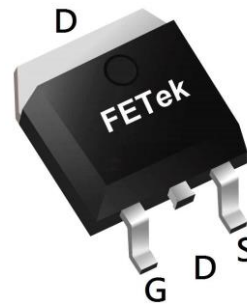

Absolute Maximum Ratings

Symbol	Parameter	Rating	Units
V_{DS}	Drain-Source Voltage	80	V
V_{GS}	Gate-Source Voltage	± 20	V
$I_D@T_C=25^\circ C$	Continuous Drain Current ^{1,6}	180	A
$I_D@T_C=100^\circ C$	Continuous Drain Current ^{1,6}	140	A
I_{DM}	Pulsed Drain Current ²	400	A
EAS	Single Pulse Avalanche Energy ³	180	mJ
I_{AS}	Avalanche Current	30	A
$P_D@T_C=25^\circ C$	Total Power Dissipation ⁴	272	W
T_{STG}	Storage Temperature Range	-55 to 175	$^\circ C$
T_J	Operating Junction Temperature Range	-55 to 175	$^\circ C$

Thermal Data

Symbol	Parameter	Typ.	Max.	Unit
$R_{\theta JA}$	Thermal Resistance Junction-Ambient ¹	---	60	$^\circ C/W$
$R_{\theta JC}$	Thermal Resistance Junction-Case ¹	---	0.55	$^\circ C/W$

Electrical Characteristics ($T_J=25^\circ\text{C}$, unless otherwise noted)

Symbol	Parameter	Conditions	Min.	Typ.	Max.	Unit
BV_{DSS}	Drain-Source Breakdown Voltage	$V_{GS}=0V, I_D=250\mu A$	80	---	---	V
$R_{DS(ON)}$	Static Drain-Source On-Resistance ²	$V_{GS}=10V, I_D=20A$	---	2.7	3.4	m Ω
$R_{DS(ON)}$	Static Drain-Source On-Resistance ²	$V_{GS}=4.5V, I_D=20A$	---	3.3	4.5	m Ω
$V_{GS(th)}$	Gate Threshold Voltage	$V_{GS}=V_{DS}, I_D=250\mu A$	1.2	---	2.3	V
I_{DSS}	Drain-Source Leakage Current	$V_{DS}=64V, V_{GS}=0V, T_J=25^\circ\text{C}$	---	---	1	μA
		$V_{DS}=64V, V_{GS}=0V, T_J=55^\circ\text{C}$	---	---	5	
I_{GSS}	Gate-Source Leakage Current	$V_{GS}=\pm 20V, V_{DS}=0V$	---	---	± 100	nA
g_{fs}	Forward Transconductance	$V_{DS}=5V, I_D=20A$	---	75	---	S
R_g	Gate Resistance	$V_{DS}=0V, V_{GS}=0V, f=1\text{MHz}$	---	0.5	---	Ω
Q_g	Total Gate Charge (10V)	$V_{DS}=40V, V_{GS}=10V, I_D=20A$	---	110	---	nC
Q_{gs}	Gate-Source Charge		---	23	---	
Q_{gd}	Gate-Drain Charge		---	17	---	
$T_{d(on)}$	Turn-On Delay Time	$V_{DD}=40V, V_{GS}=10V, R_G=3.3\Omega, I_D=20A$	---	15	---	ns
T_r	Rise Time		---	22	---	
$T_{d(off)}$	Turn-Off Delay Time		---	46	---	
T_f	Fall Time		---	26	---	
C_{iss}	Input Capacitance	$V_{DS}=40V, V_{GS}=0V, f=1\text{MHz}$	---	6304	---	μF
C_{oss}	Output Capacitance		---	1647	---	
C_{rss}	Reverse Transfer Capacitance		---	62	---	

Diode Characteristics

Symbol	Parameter	Conditions	Min.	Typ.	Max.	Unit
I_S	Continuous Source Current ^{1,5}	$V_G=V_D=0V, \text{Force Current}$	---	---	100	A
V_{SD}	Diode Forward Voltage ²	$V_{GS}=0V, I_S=20A, T_J=25^\circ\text{C}$	---	0.9	1.2	V
t_{rr}	Reverse Recovery Time	$I_F=20A, di/dt=400A/\mu s,$	---	57	---	nS
Q_{rr}	Reverse Recovery Charge	$T_J=25^\circ\text{C}$	---	189	---	nC

Note :

- 1.The data tested by surface mounted on a 1 inch² FR-4 board with 2OZ copper.
- 2.The data tested by pulsed , pulse width $\leq 300\mu s$, duty cycle $\leq 2\%$
- 3.The EAS data shows Max. rating . The test condition is $V_{DD}=50V, V_{GS}=10V, L=0.4mH, I_{AS}=30A$
- 4.The power dissipation is limited by 175°C junction temperature
- 5.The data is theoretically the same as I_D and I_{DM} , in real applications , should be limited by total power dissipation.
- 6.The maximum current rating is package limited.

Typical Characteristics

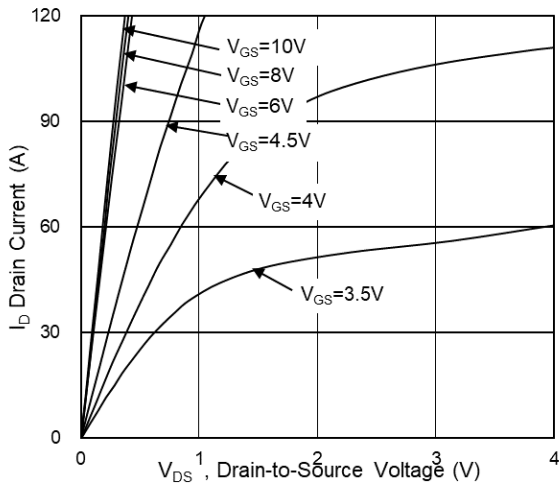

Fig.1 Typical Output Characteristics

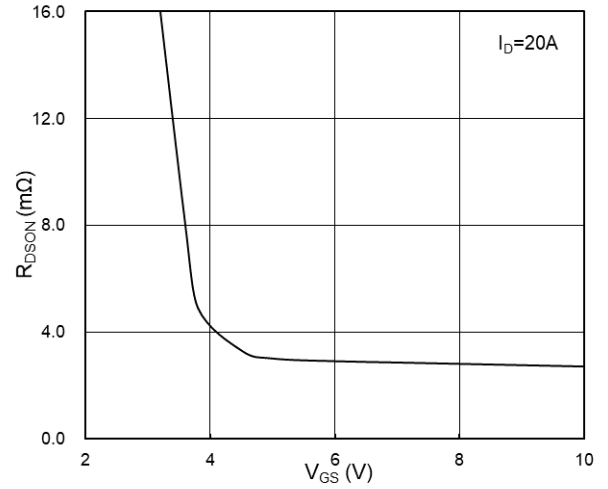

Fig.2 On-Resistance vs G-S Voltage

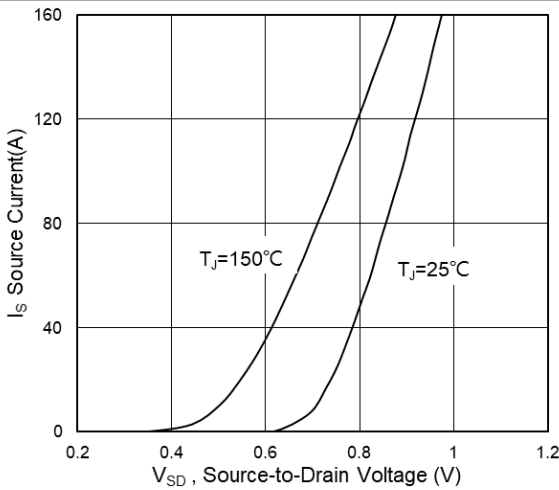

Fig.3 Source Drain Forward Characteristics

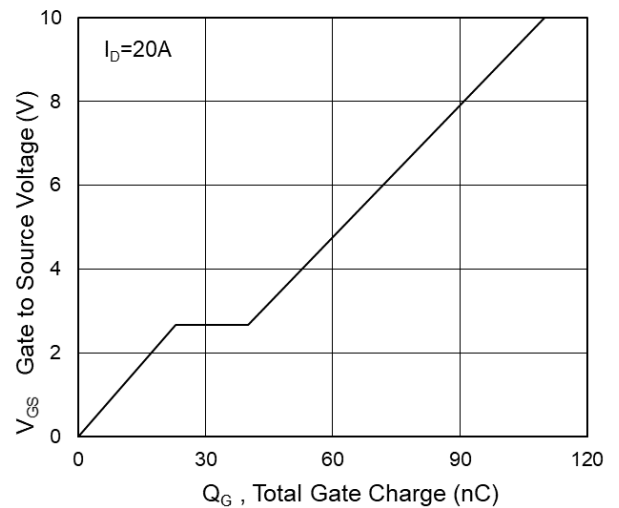

Fig.4 Gate-Charge Characteristics

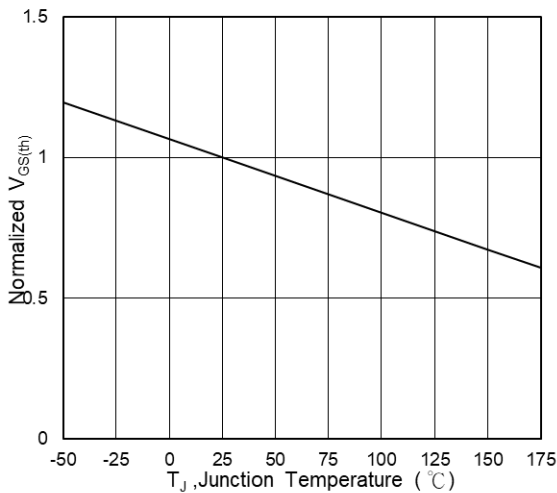

Fig.5 Normalized $V_{GS(th)}$ vs T_J

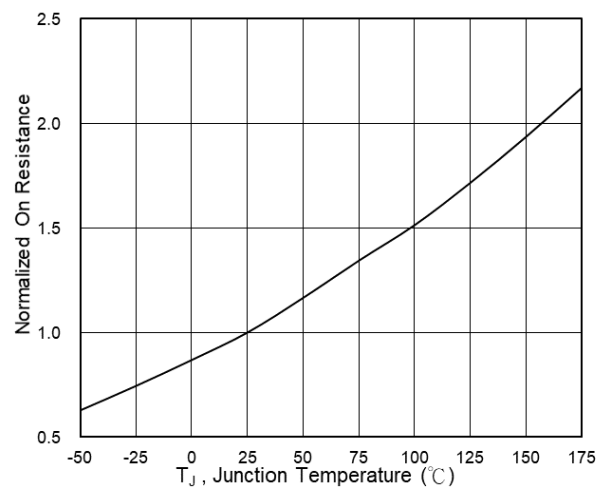

Fig.6 Normalized $R_{DS(on)}$ vs T_J

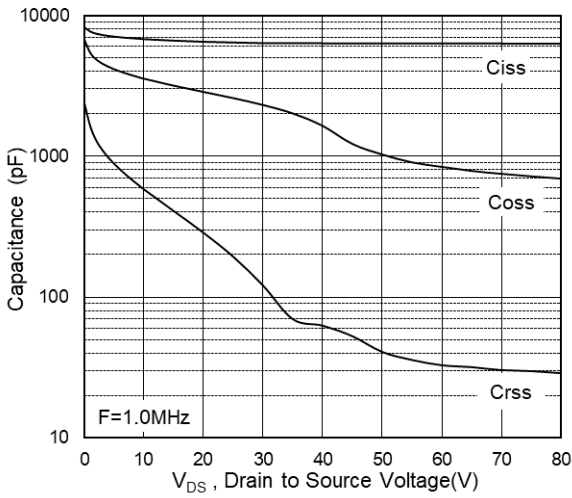

Fig.7 Capacitance

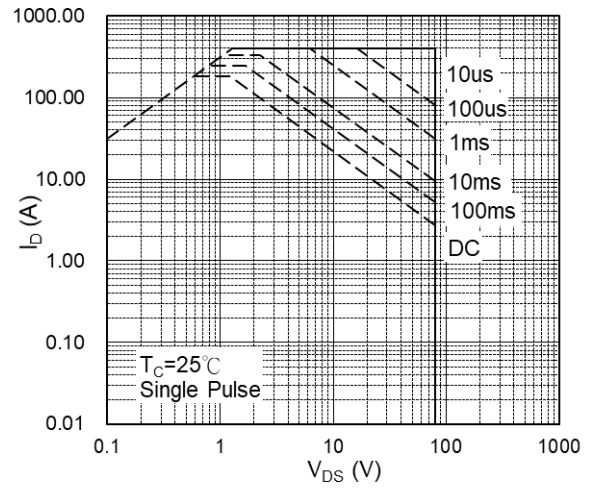

Fig.8 Safe Operating Area

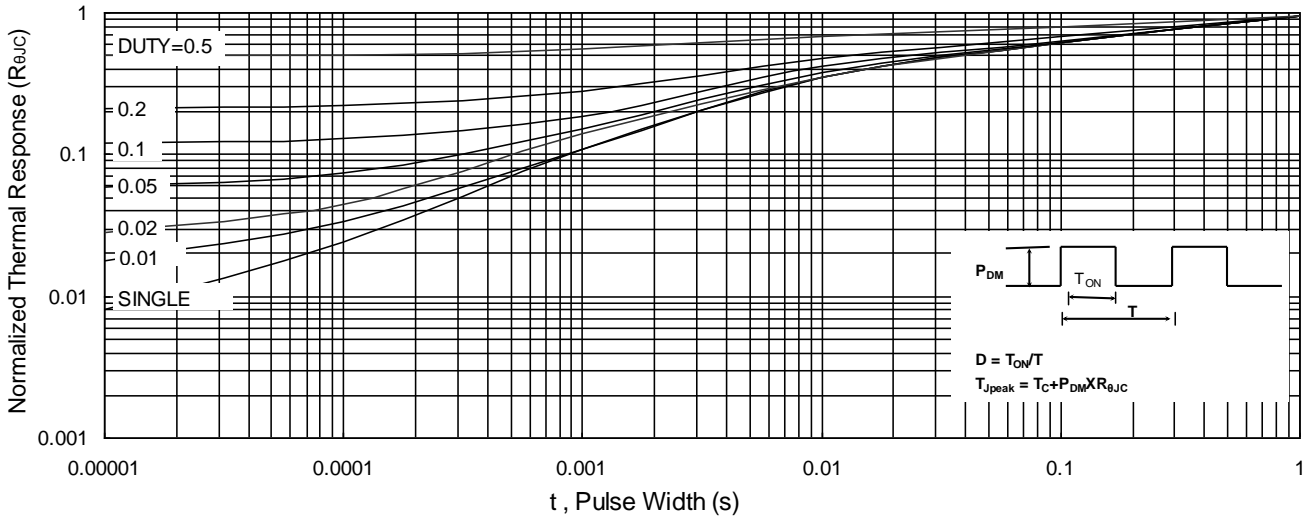

Fig.9 Normalized Maximum Transient Thermal Impedance

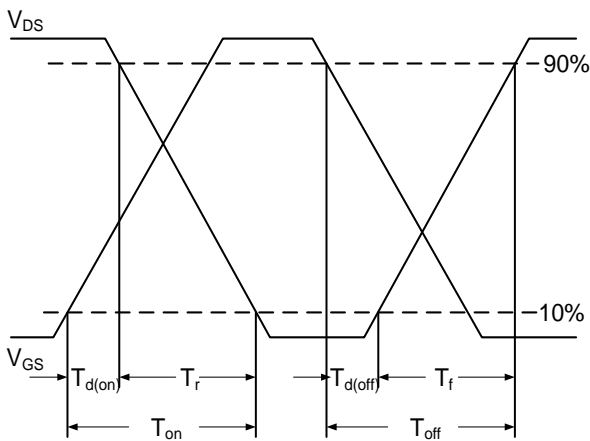

Fig.10 Switching Time Waveform

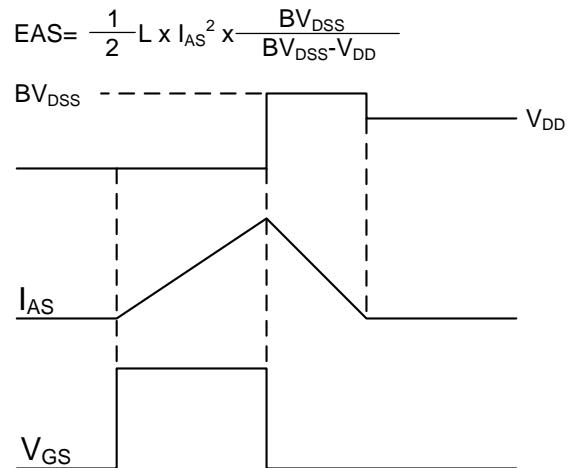

Fig.11 Unclamped Inductive Switching Waveform